

DXGM 25-11

Teknisk specifikation

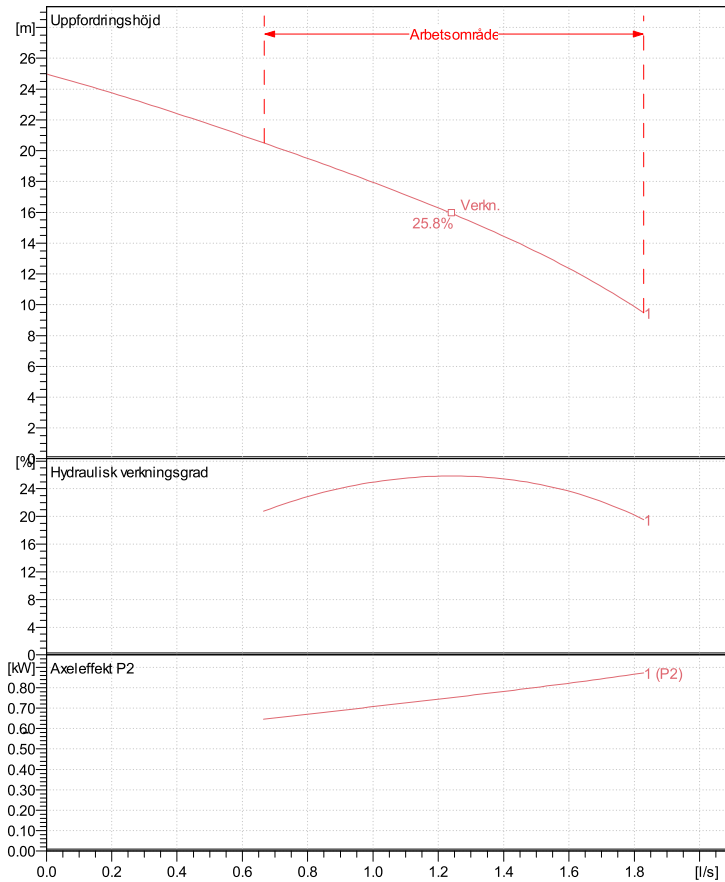

Note: Picture might not correspond to the current configuration.

Impeller

Impeller diameter 0 mm

Motor

Motor # SA 110M71D
 Frekvens 50
 Märkspänning 230 V
 Polpar 1
 Faser 1~
 Märkeffekt 1.1 kW
 Märkström 7.02 A
 Nominellt varvtal 2900 rpm

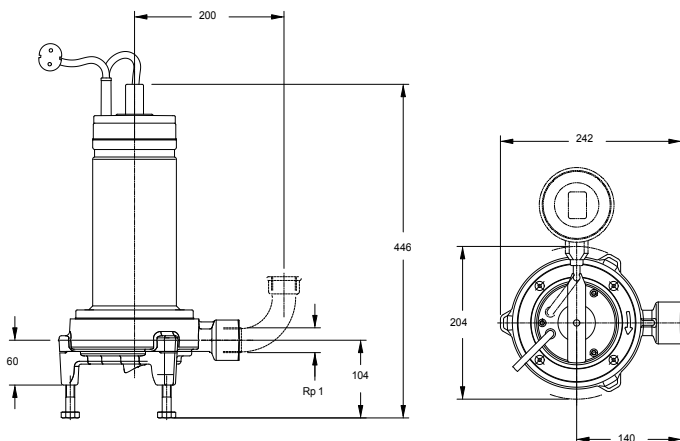

Dimension	mm
H	446
H1	104
H2	296
H3	135
L	508

DXGM 25-11

Kurvkod

Pump

Impeller diameter 0 mm

Motor

Motor #	SA 110M71D
Frekvens	50 Hz
Rated voltage	230 V
Antal poler	2
Fasor	1~
Märkeffekt	1.1 kW
Märkström	7.02 A
Nominellt varvtal	2900 rpm

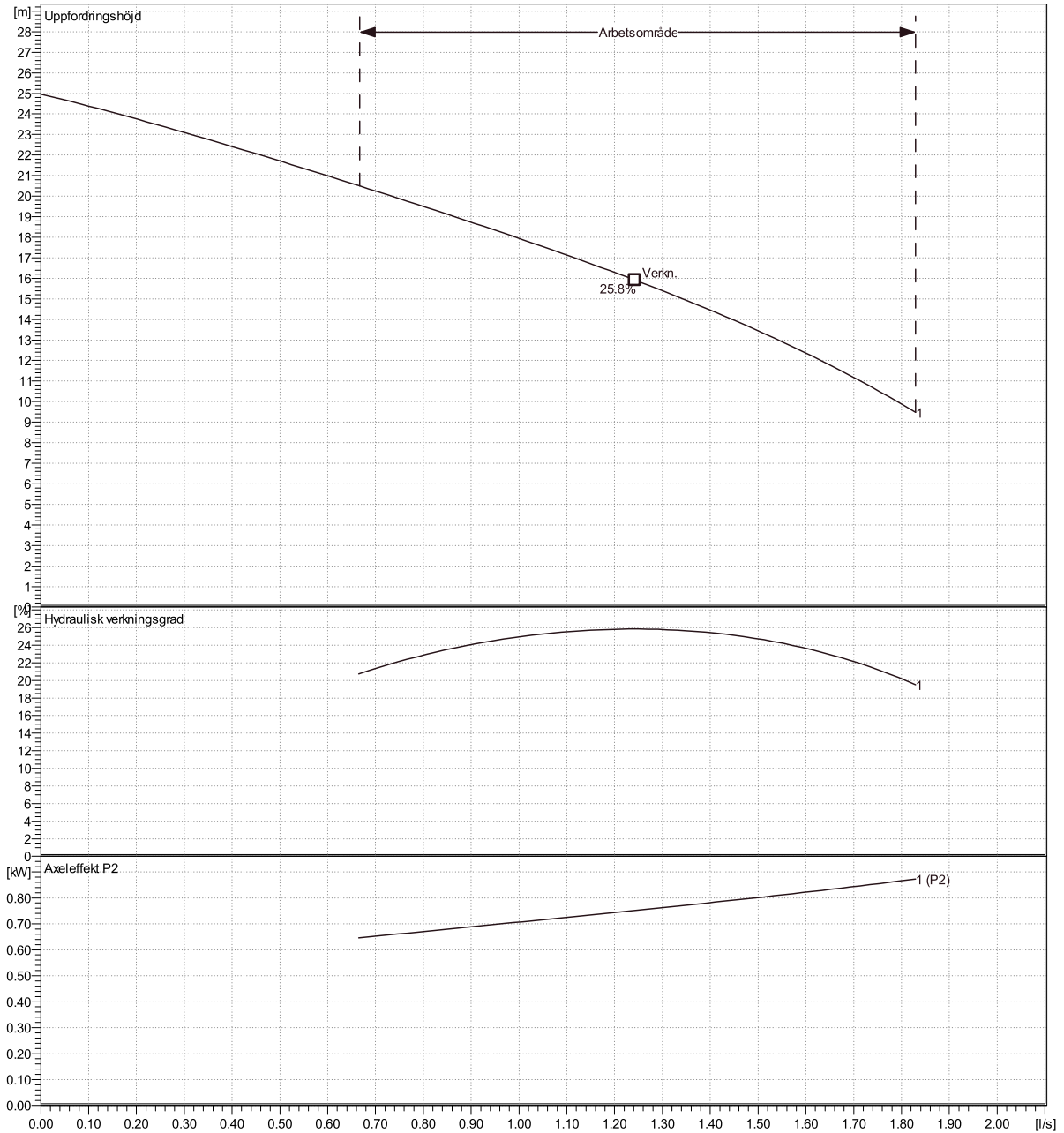

Curve ISO